

Memory

# MRAM

## Technical Guide

### Overview

Freescale's magnetoresistive random access memory (MRAM) products combines magnetic storage elements with a standard complementary-metal-oxide-semiconductor (CMOS) logic process to obtain the benefits of high density, low cost, non-volatility, SRAM speed and unlimited read/write endurance, a combination not found in other existing volatile or non-volatile memory technologies.

Freescale MRAM products employ a one transistor, one magnetic tunnel junction (MTJ) memory cell (Figure 1). MRAM products are currently fabricated using a 180 nm CMOS process using five levels of metal, including program lines clad with highly permeable material for magnetic flux concentration. The patented Freescale architecture, bit structure and toggle mode storage technique deliver nvRAM products with the best price/performance and highest reliability.

Figure 1

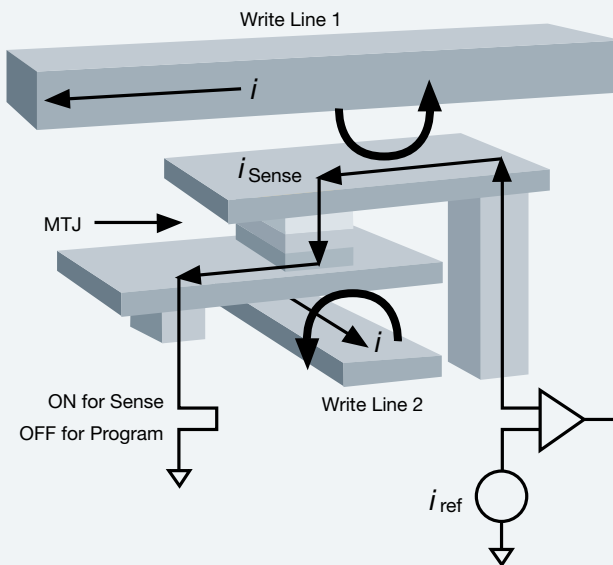

Figure 1. Schematic of a 1-transistor, 1-MTJ memory cell showing the write lines above and below the bit and the read current path.

## MRAM Description

MRAM is based on magnetic storage elements integrated with CMOS processing. Each storage element uses a magnetic tunnel junction (MTJ) device. The MTJ is composed of a fixed magnetic layer, a thin dielectric tunnel barrier and a free magnetic layer. When a bias is applied to the MTJ, electrons that are spin polarized by the magnetic layers traverse the dielectric barrier through a process known as tunneling. The MTJ device has a low resistance when the magnetic moment of the free layer is parallel to the fixed layer and a high resistance when the free layer moment is oriented antiparallel to the fixed layer moment. This change in resistance with the magnetic state of the device is an effect known as magnetoresistance, hence the name “magnetoresistive” RAM.

Unlike most other semiconductor memory technologies, the data is stored as a magnetic state rather than a charge and sensed by measuring the resistance without disturbing the magnetic state. Using a magnetic state for storage has two main benefits. First, the magnetic polarization does not leak away with time like charge does, so the information is stored even when the power is turned off. And second, switching the magnetic polarization between the two states does not involve actual movement of electrons or atoms and thus no known wear-out mechanism exists. The magnetoresistive device used in MRAM is very similar to the device used for the read head of magnetic hard disk drives.

To make a high-density memory, the MRAM cells shown in Figure 1 on the previous page are arranged in a matrix with each write line spanning hundreds or thousands of bits, as shown in Figure 2. During the write operation, current pulses are passed through a digit line and a bit line, writing only the bit at the cross point of those two lines. During the read operation, the target bit’s isolation transistor is turned on to bias the MTJ and the resulting current is compared to a reference to determine if the resistance state is low or high.

## MRAM Toggle Bit

Freescale’s toggle approach to bit programming effectively eliminates the singleline disturb phenomenon that exists in previous approaches to MRAM switching. Through the use of a new free layer structure, bit orientation and current pulse sequence, the MRAM bit state can be programmed via a “Savtchenko switching toggle”

Figure 2

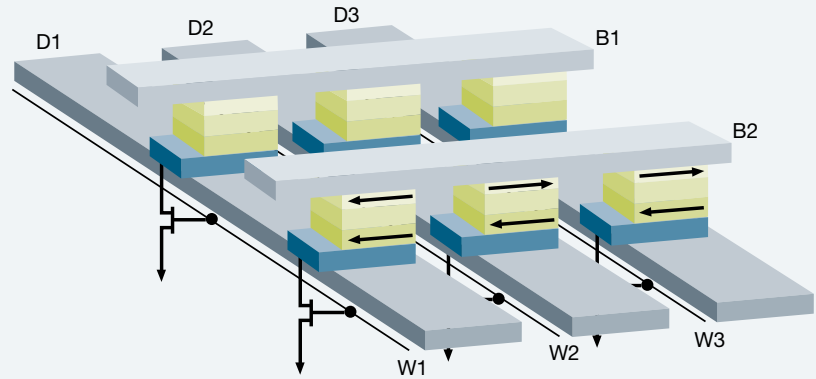

Figure 2. A memory array consisting of many MRAM cells with digit and bit lines for cross-point writing and isolation transistors controlled by word lines.

Figure 3

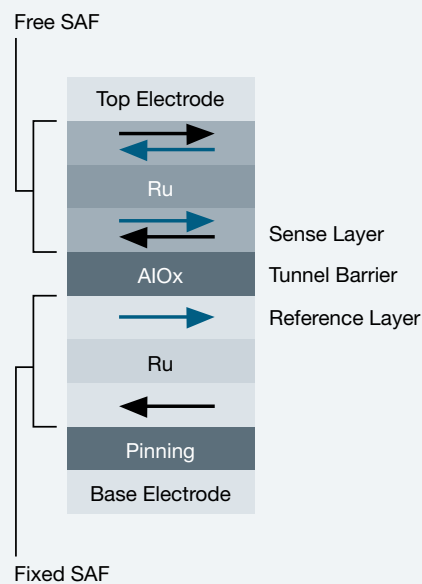

Figure 3. The magnetic tunnel junction (MTJ) material stack used for Toggle MRAM. The Free SAF magnetic moments switch between two states when the proper magnetic field sequence is applied. Electrons tunnel across the alumina (AlOx) tunnel barrier, resulting in a magnetoresistance that is sensitive to the magnetic moment direction of the sense layer.

mode, named after its late inventor. “Toggle” means that the exact same pulse sequence is used to write from the “0” state to the “1” state and for “1” to “0.” Each time the sequence is executed the device changes from its current magnetic state to the opposite state. This type of switching is significantly different from the simple type of switching where the free layer’s magnetic moment simply follows the applied field. Because the switching mode is fundamentally different, the selectivity is greatly enhanced as described below. Savtchenko switching relies on the unique behavior of a synthetic antiferromagnet (SAF) free layer that is formed from two ferromagnetic layers separated by a nonmagnetic coupling spacer layer. This is shown schematically in Figure 3. The moment-balanced SAF freelaye responds to an applied magnetic field differently than the single ferromagnetic layer of conventional MRAM. Rather than following an applied magnetic field, the two anti-parallel layer magnetizations will rotate to be approximately orthogonal to the applied field. A current pulse sequence is used to generate a rotating magnetic field that moves the free-layer moments through the 180-degree switch from one state to the other, as shown in Figure 4. To exploit the unique field response of this free layer, a two-phase programming pulse sequence, shown in Figure 5, is applied to effectively rotate the magnetic moments of the SAF by 180 degrees. Because of the inherent symmetry, this sequence toggles the bit to the opposite state regardless of existing state. A

Figure 4

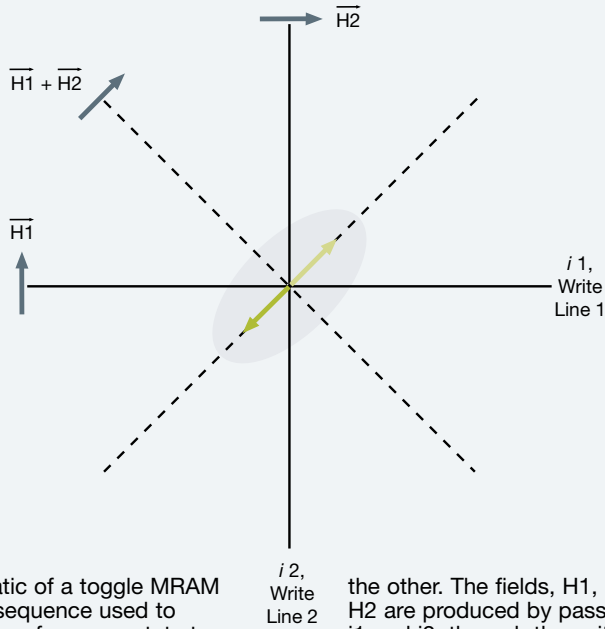

Figure 4. Schematic of a toggle MRAM bit with the field sequence used to switch the free layer from one state to

the other. The fields,  $H_1$ ,  $H_1+H_2$  and  $H_2$  are produced by passing currents,  $i_1$  and  $i_2$ , through the write lines.

pre-read is therefore used to determine if a write is required. Because of the way a SAF responds to applied fields, a single line alone cannot switch the bit, providing greatly enhanced selectivity over the previous approaches to MRAM switching. Figure 6 is a switching characteristic map versus current for an entire 4 MB memory. In the region below the switching threshold, no bits changed state and there are no disturbs from half-selects. A large operating region is observed above the threshold consistent with the single bit characteristic presented above. The contours in the transition region just at the threshold are a measure of the bit-to-bit switching distribution. Note that there are no disturbs all the way up to the highest currents, displaying the remarkable resistance to singleline disturbs with this approach.

### Comparison with Other Memory Technologies

Comparing MRAM with other memory technologies suggests that it can be competitive in overall performance. Since MRAM is nonvolatile, it retains the data when completely turned off. Since background refreshing is not required, MRAM can be shut down when inactive, significantly reducing system power consumption when compared to DRAM. The straightforward integration scheme used for MRAM also makes it easier to embed. Compared to SRAM, MRAM is more cost effective due to its smaller cell size. It is also

Figure 5

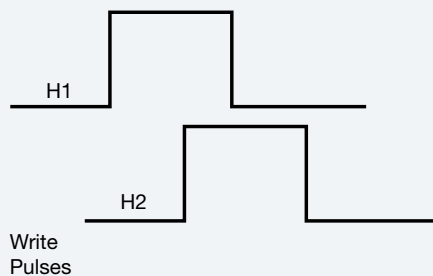

Figure 5. The current pulse sequence used to produce the sequence of magnetic fields used for toggle switching.

Figure 6

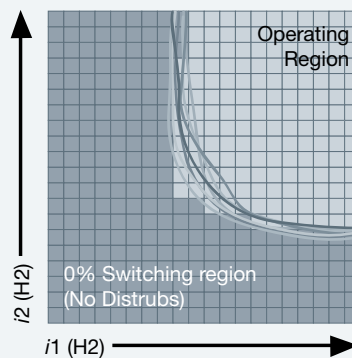

Figure 6. Measured toggling characteristic map of an entire 4 MB die showing the large operating region.

nonvolatile, which is only available for SRAM in more complex and expensive battery backup solutions. MRAM achieves much better write performance than flash since no high-voltage tunneling mode is required. The MRAM write cycle is much faster and consumes much less energy because the energy per bit is several orders of magnitude lower than flash. In addition, MRAM has unlimited endurance, with no known deterioration mechanism, while typical flash endurance is  $10^5$  read/write cycles.

### External Magnetic Fields and MRAM

MRAM products are designed and specified to prevent changes to stored data for externally applied external magnetic fields of  $<15$  Gauss (Oersted). As a comparison, the earth's magnetic field at its surface is less than 0.5 Gauss and the Occupational Safety and Health Administration (OSHA) require a posted warning for areas around instruments that exceed 5 Gauss. As is evident, the specification for MRAM products exceeds these values by a wide margin. There are two main sources of magnetic fields—current-carrying wires and permanent magnetic materials. In each case, the source's geometry determines the extent of the magnetic field and its magnitude, field at considerable distances from the field's source. The following is designed to familiarize the reader with examples of these sources and the resultant magnetic field profiles.

The first example is a straight wire carrying 200 Amps, such as a starter cable for an engine with a cross-section of 1.5 centimeters. As is shown in Table 1, the field's magnitude decays rapidly with distance and only exceeds the spec for MRAM products within approximately 2 centimeters of the wire surface. For currents more realistic to circuit boards, such as 1 Amp, this data can be scaled to produce fields less than 10 Gauss at distances greater than 0.2 millimeters from the conductor. Magnetic fields greater than the MRAM's 15 Gauss specification are unusual and can be further enhanced by system design.

The second example is a hard permanent magnet, such as a refrigerator magnet or one found in a cellular phone speaker. For example, in a Motorola StarTac® cellular phone the highest magnitude of measured magnetic field was 90 Gauss directly at the surface of the speaker. However, within 5 millimeters of the surface the field was less than 10 Gauss and negligible beyond 1 centimeter. The MRAM's applied external magnetic field specification is

15-25 Gauss (Oersted) during writes and 100 Gauss (Oersted) during reads. This magnitude should not require special design consideration in most applications and minimal physical layout optimization in special cases. Gaussmeters are commercially available that can verify that the specification is met for specific applications.

### Integration of Magnetic Devices with CMOS

A schematic cross-sectional view of Freescale's integrated MRAM cell for a 1T-1MTJ cell architecture is shown in Figure 7. The MRAM process module is integrated between the last two layers of metal in an otherwise standard semiconductor process flow. The MRAM module is termed a "backend" module because it is inserted after all of the associated CMOS circuitry has been fabricated. This integration scheme requires no alteration to the front-end CMOS process flow. This back-end approach separates the specialized magnetic materials processing from the standard CMOS process. This integration scheme lends itself to embedded application where the memory core is part of a non-memory circuit such as a processor or controller. For example, a processor may need to have some fast memory and some non-volatile memory on board—MRAM can provide both capabilities. Because the MRAM module is independent of the front-end CMOS, the MRAM capability can be added without perturbing the CMOS logic process. This approach provides cost and performance advantages in many system-on-chip applications.

Figure 7

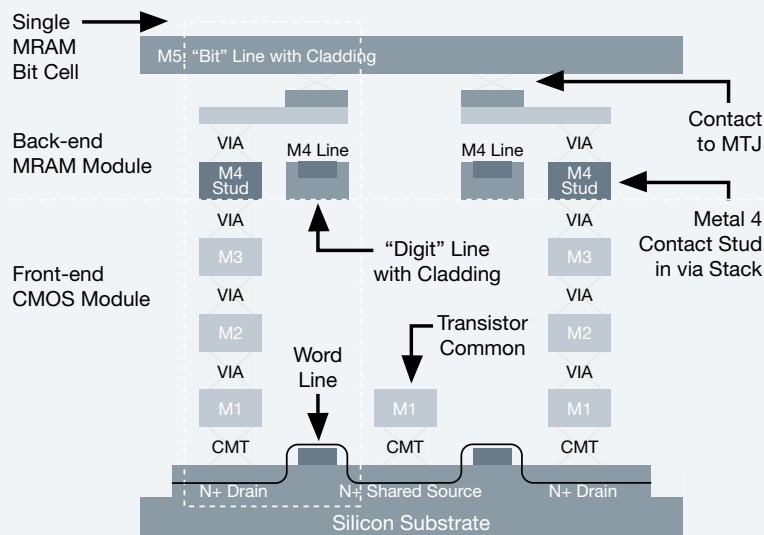

Figure 7. A schematic cross-sectional view of Freescale's integrated MRAM cell for a 1T-1MTJ cell architecture. The MRAM module is inserted after the front-end CMOS (above the horizontal red line).

### Conclusion

Freescale's MRAM is a revolutionary memory product that provides the highest density, the best price/performance, and highest reliability of all nvRAM product alternatives.

The underlying MRAM technology is well positioned to supply high density, low cost embedded memory capable of replacing Flash, SRAM, and EEPROM with a single unified memory in many future microcontroller products.

Table 1. Magnetic field strength as a function of distance.

Distance from center of a wire in cm.	Magnetic field in Gause (Oersted)
2	20.0
3	13.3
4	10.0
5	8.0
6	6.7
7	5.7
8	5.0
9	4.4
10	4.0

### Learn More:

For current information about Freescale products and documentation, please visit [www.freescale.com/MRAM](http://www.freescale.com/MRAM).